



1/113 Queenscliff Road QUEENSLIFF, NSW 2 1 1

Two generous double bedrooms both with built in robes

Live a lifestyle second to none in this tastefully renovated apartment situated just moments from Queenscliff and Freshwater beaches, cafes and transport. Offering two double bedrooms, balcony, modern kitchen, full bathroom, district views, car space and storage.

- Two generous double bedrooms both with built in robes
- Ideal floor plan with open living area flowing onto balcony
- As new Polyurethane kitchen with European appliances
- Full bathroom
- Minutes walk from Queenscliff and Freshwater beaches
- District views over Manly and Fairlight
- Under cover car space on title
- Additional secure communal storage
- Transport at front door - an opportunity not to be missed

Price: Over \$420,000

Stone Manly

02 8962 2200

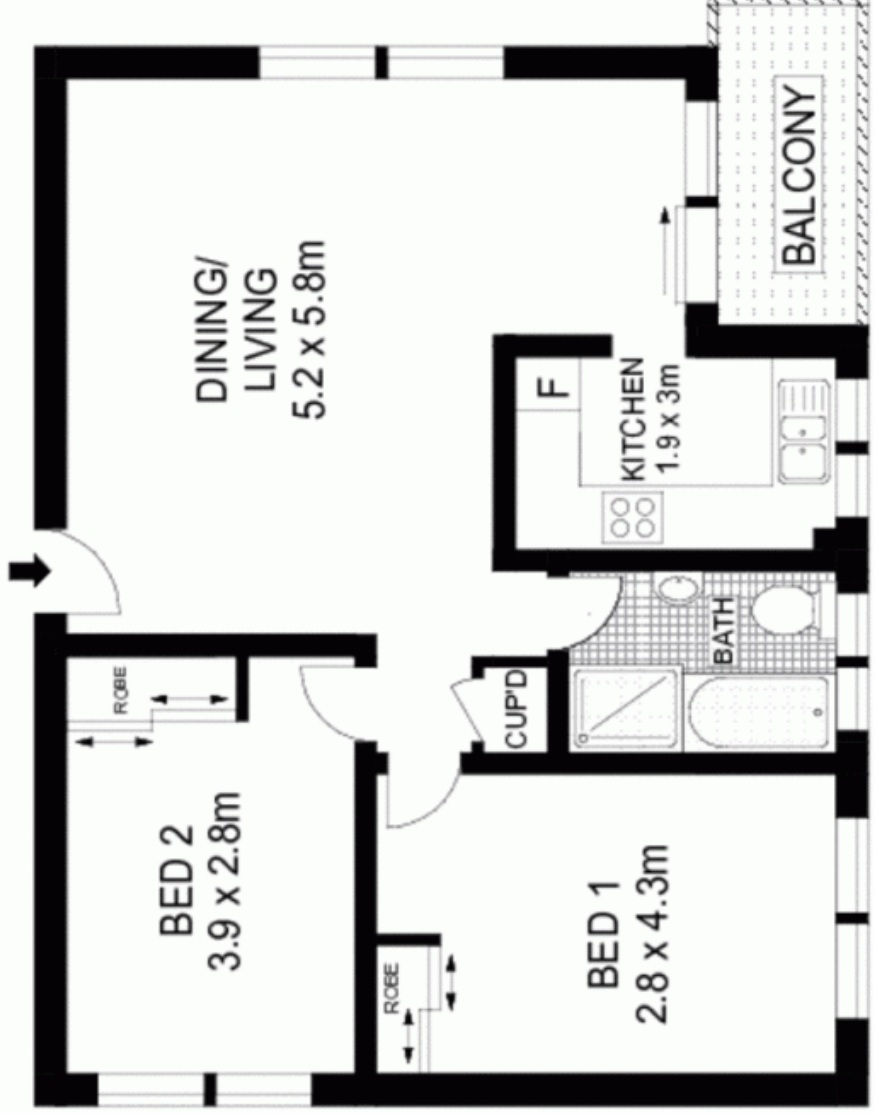
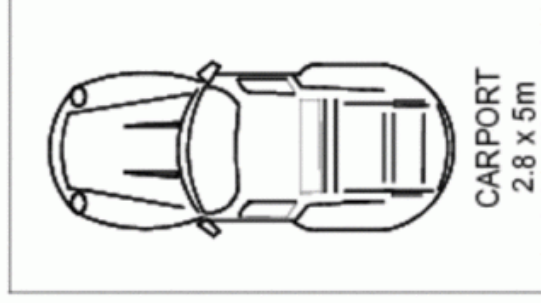

ELAVATED GROUND FLOOR

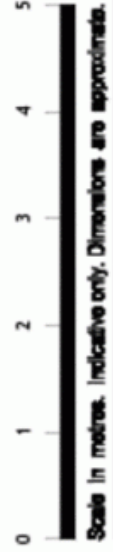

1/113 Queenscliff Road, Queenscliff

McGrath