

6/24 Wood Street MANLY, NSW

3

2

2

Short stroll from Little Manly Beach and Manly Wharf

Gaze along the length of the harbour from this superbly appointed apartment situated in the peaceful heart of Manly's exclusive Eastern Hill. Blessed with multiple balconies and northerly sunlight, it is an inspiring haven for both relaxing or entertaining

Short stroll from Little Manly Beach and Manly Wharf

Moments from Manly Beach and choice of colourful eateries

Nestled in a boutique block amidst landscaped gardens

Spacious living area warmed by a cosy gas log fire

Living opens to a wide terrace with stunning harbour views

Separate dining space opens to a private sunlit balcony

Open plan chefs kitchen with sleek black granite benches

Three bedrooms with built-ins, master with ensuite and robe

Stylish new contemporary bathrooms, main with spa bath

Double security parking, internal laundry, Brushbox flooring

Price:

Over
\$760,000

Stone Manly

02 8962 2200

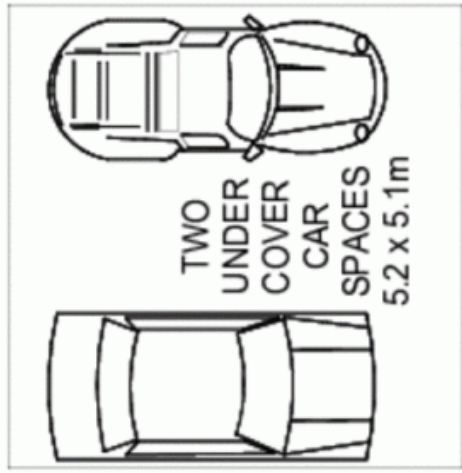
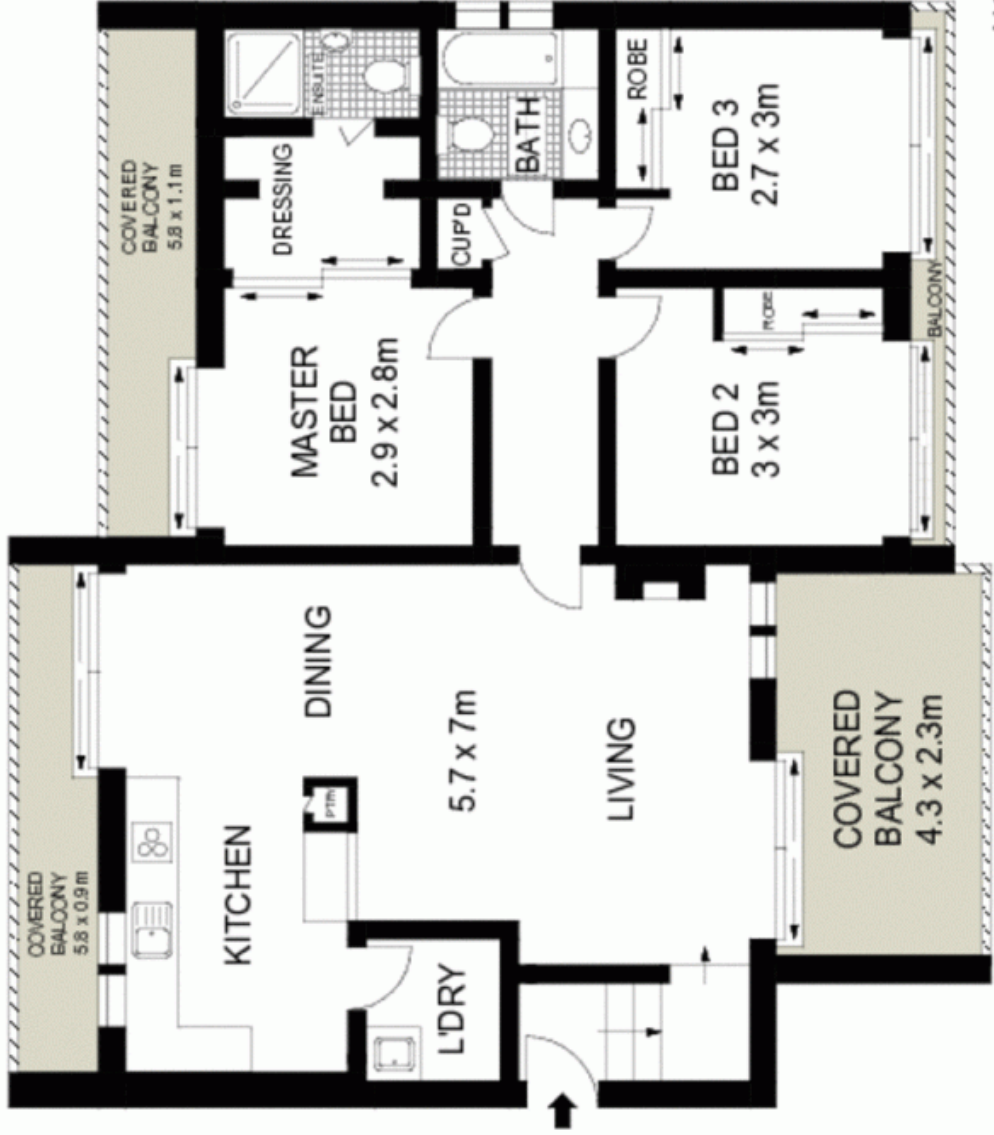

NOTE: TWO UNDER COVER CAR SPACES

TOP FLOOR



Scale in metres. Indicative only. Dimensions are approximate. All information contained herein is gathered from sources we believe to be reliable. However, we cannot guarantee its accuracy and interested persons should rely on their own enquiries.

McGrath

6/24 Wood Street, Manly