



18/1064-1070 Old Princes Highway Engadine, NSW



### Superb location

This ground floor beauty has been updated, featuring neutral interiors and timber look flooring. Located right in the heart of Engadine, and the many great opportunities this wonderful community has to offer, this two-bedroom apartment is perfect for first home buyers, downsizers and investors alike, an opportunity not to be missed.

**Price:** Contact Agent  
**Council Rates:** \$354.00 p/q  
**Water Rates:** \$151.00 p/q  
**Strata Rates:** \$620.00 p/q



**Rhys Christofa**

0415 684 877



**Lisa Hale**

0417 418 250

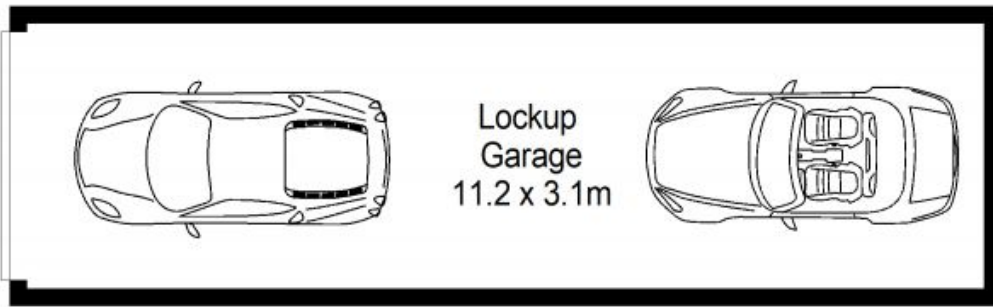

**BASEMENT**

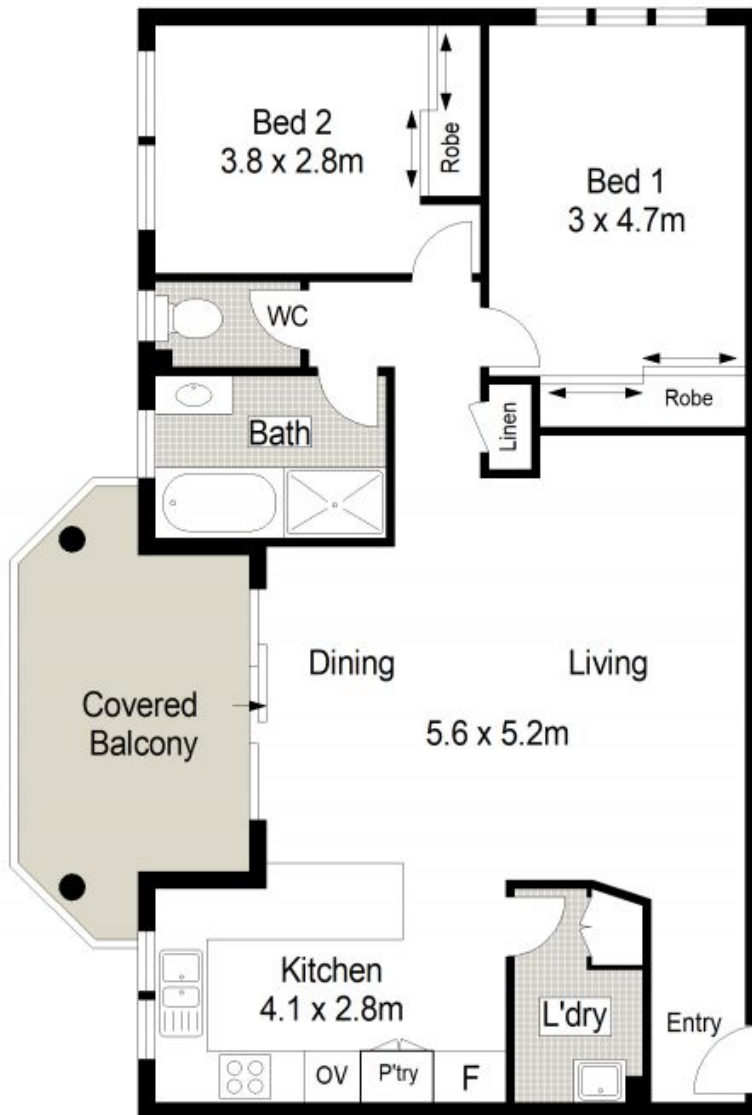

**GROUND FLOOR**

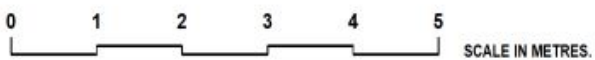

Scale in metres. Indicative only. Dimensions are approximate. All information contained herein is gathered from sources we believe to be reliable. However we cannot guarantee its accuracy and interested persons should rely on their own enquiries.