



2/2 Eaton Street NEUTRAL BAY, NSW



Stylishly Renovated Apartment in a Quiet Ultra-Convenient Locale

This charming character 2 bedroom strata apartment has been elegantly modernised, blending open plan lifestyle living with traditional character features.

Stone Real Estate -
Head Office

Apartment Size

90 sqm internal approx
12 sqm garage approx

Outgoings

Strata Rates - \$1333 pq approx
Water Rates - \$175 pq approx
Council Rates - \$223 pq approx

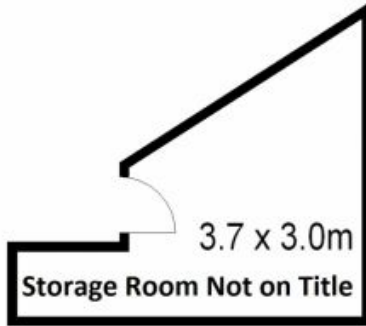

GROUND FLOOR

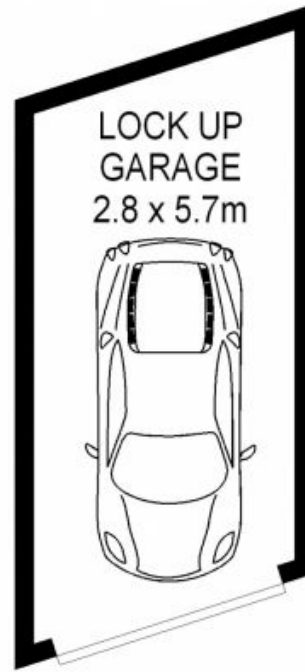

GROUND FLOOR

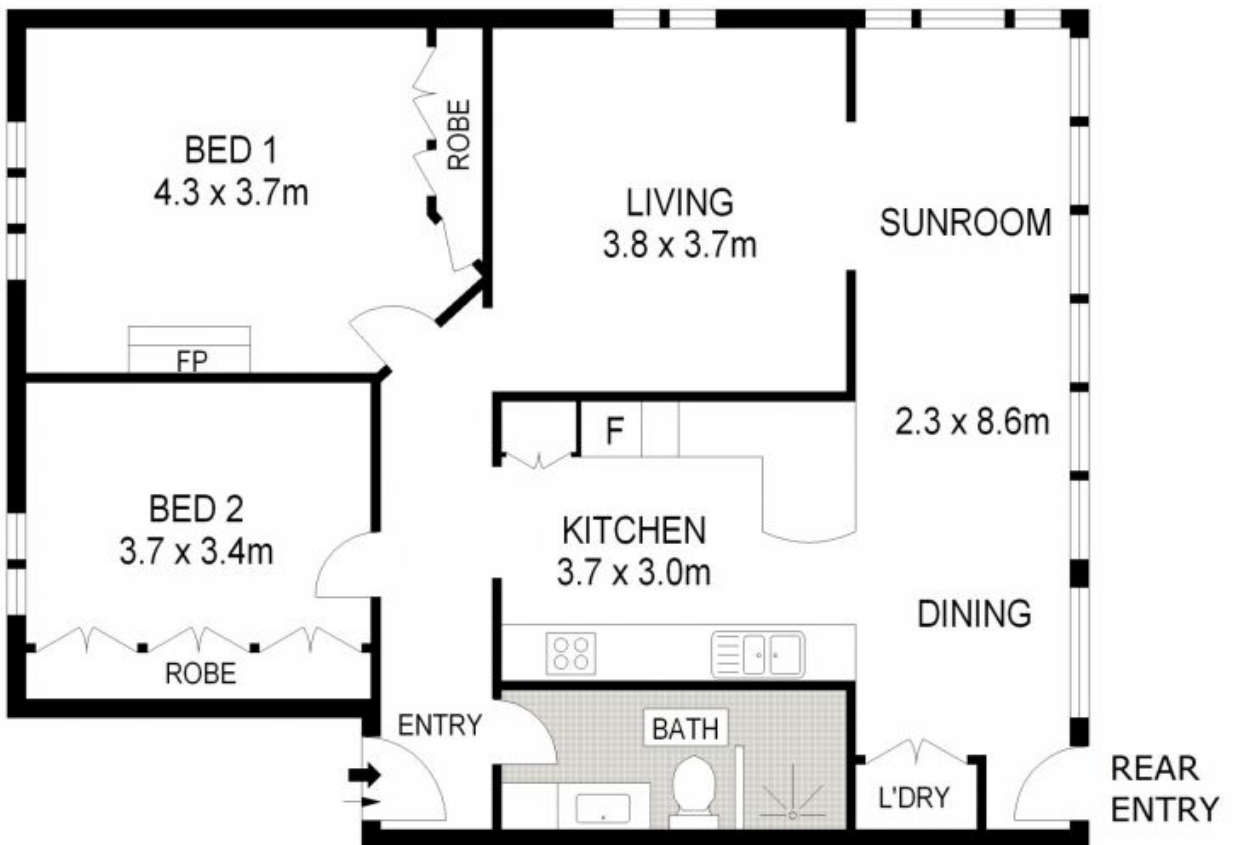

PLANS SHOWN ONLY INDICATIVE Disclaimer: Indicative only. Dimensions are approximate. All information contained herein is gathered from sources we believe to be reliable. However we cannot guarantee its accuracy and interested persons should rely on their own inquiries.