



5/14 New Street North Parramatta, NSW



Well Presented Two Bedroom Apartment

This tastefully updated two-bedroom apartment boasts a sought-after location with effortless access to a variety of local amenities, including the newly opened light rail right outside. Set within a secure, well-maintained building of only six units, this property offers both comfort and privacy. Featuring sophisticated interiors, it is ideal for those seeking a convenient lifestyle. Just moments from Parramatta's CBD, shopping centres, business hubs, and entertainment venues, and within walking distance to top-rated schools, cafes, restaurants, and Westfield Shopping Centre.

Price: \$600.00 pw

Available Date: 24/02/2025



Jason Assaf

0416 589 096

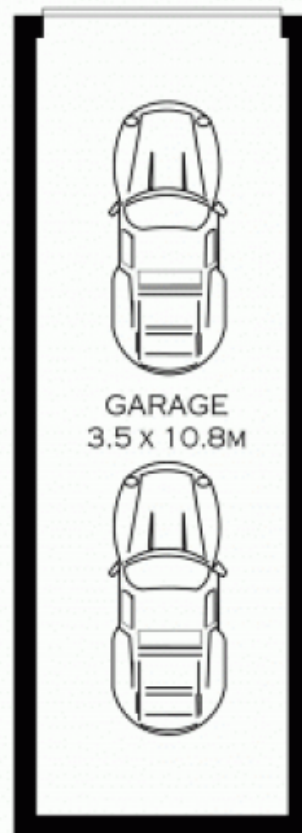
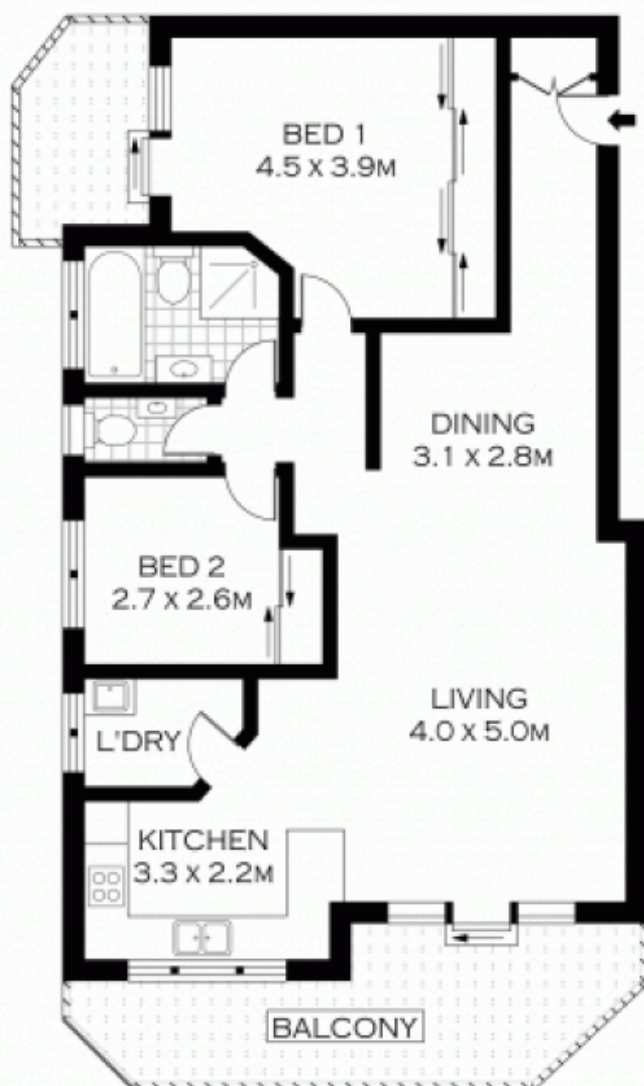

NOTE: TANDEM LOCK-UP GARAGE



PLANS SHOWN ONLY INDICATIVE OF LAYOUT. DIMENSIONS ARE APPROXIMATE.
 FLOOR PLANS BY WWW.REALESTATEMARKETINGAUSTRALIA.COM.AU
 Ref. No: 4009



5/14 NEW STREET

NORTH PARRAMATTA

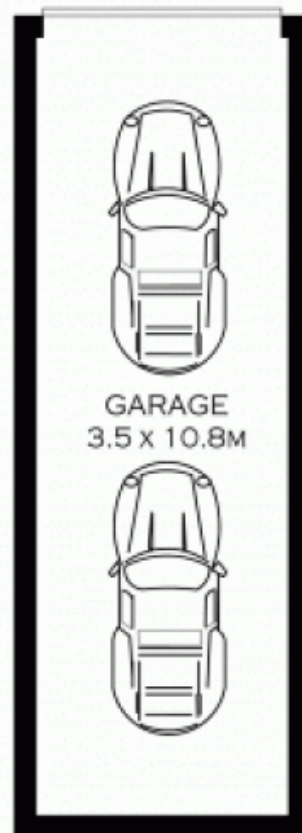
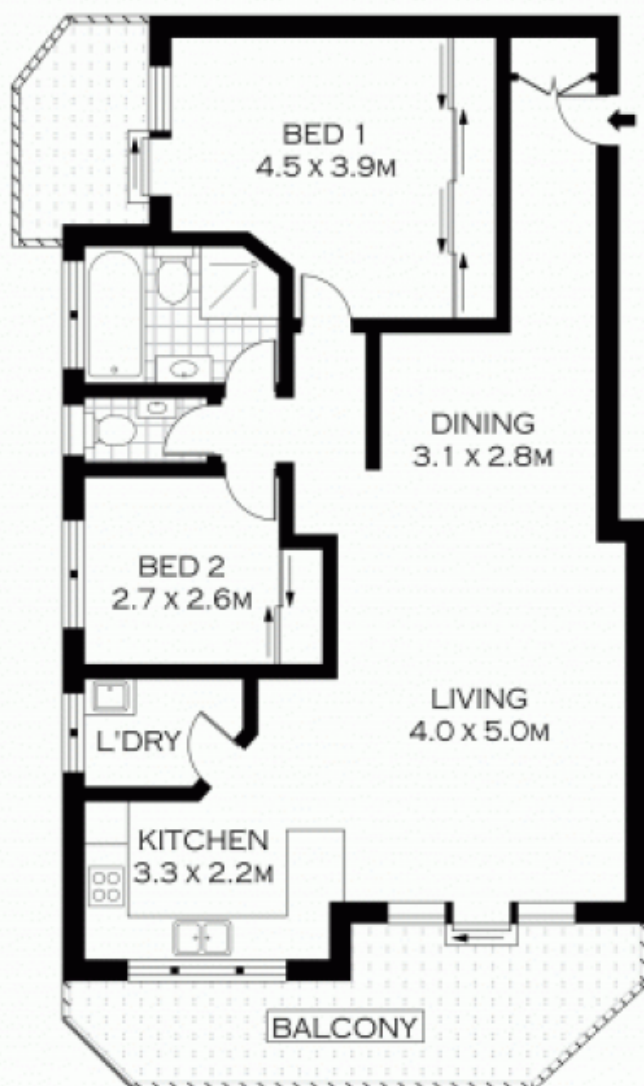

NOTE: TANDEM LOCK-UP GARAGE



PLANS SHOWN ONLY INDICATIVE OF LAYOUT. DIMENSIONS ARE APPROXIMATE.
 FLOOR PLANS BY WWW.REALESTATEMARKETINGAUSTRALIA.COM.AU
 Ref. No: 4009



5/14 NEW STREET

NORTH PARRAMATTA